

**NEMA 1 ENCLOSURE**

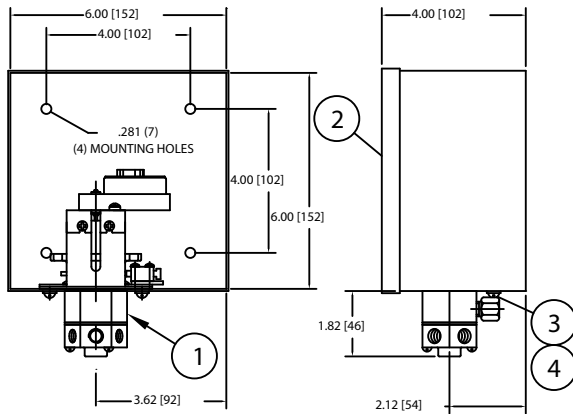

**NEMA 4 ENCLOSURE**

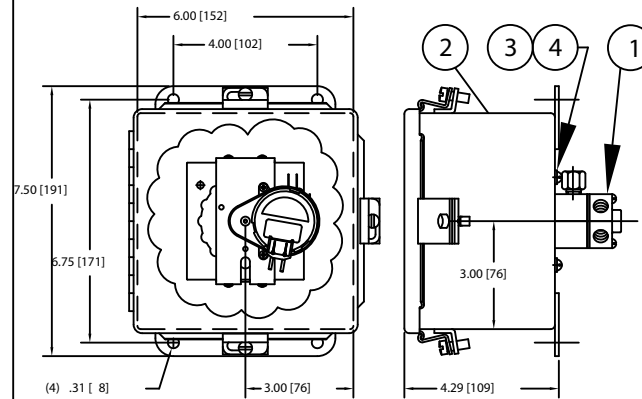

NO.	DESCRIPTION	PART NO.	QTY.
1	STAGER ASSEMBLY	R048-_-B	1
2	ENCLOSURE	NEMA 1	1075751
		NEMA 4	1077966
		NEMA 4XFG	1077969
3	PAN HEAD MACHINE SCREW 10-32 x 1/2" LONG	1075758 (510-BU)	2
4	LOCKWASHER (NO. 10)	1073588 (WAS-0005)	2

- NOTE:**
1. STAGERS CAN BE MANUALLY ADVANCED BY ROTATING THE CAM CLOCKWISE.
  2. PIPING SCHEMATICS AVAILABLE UPON REQUEST.
  3. ALL STAGERS EXCEPT 48-03 & 48-TA SUPPLIED WITH NOTCHED CAM FOR PULSE OUTPUT TYPE TIMERS. 48-03 & 48-TA SUPPLIED WITH BUTTERFLY CAM FOR "UP/DOWN" OUTPUT TYPE TIMERS.

INCHES [MILLIMETERS]

SERIES NO.	PORTS VENTED IN POSITION						DESCRIPTION
	A	B	C	D	E	F	
48-00	1,2 (SVC)	-	3,4 (BW)	-	5,6 (BR)	1,6 (FR)	4 POS. SOFTENER
48-01	1,2 (SVC)	-	3,4 (BW)	-	-	1,6 (FR)	3 POS. FILTER
48-03	1,2 (SVC)	-	3,4 (BW)	-	5,6 (BR)	1,6 (FR)	4 POS. SOFTENER (SEE NOTE 3)
48-04	1,2 (SVC)	-	3,4 (BW)	-	-	-	2 POS. FILTER
48-12	1,2 (SVC)	-	3,4 (BW)	4,5 (BR)	-	1,6 (FR)	4 POS. SOFTENER W/UPFLOW BRINE
48-83	2 (BW)	3 (BW)	-	-	6 (SVC)	1 (BW)	3 TANK SEQUENTIAL FILTER
48-84	2 (BW)	3 (BW)	4 (BW)	-	6 (SVC)	1 (BW)	4 TANK SEQUENTIAL FILTER
48-85	2 (BW)	3 (BW)	4 (BW)	5 (BW)	6 (SVC)	1 (BW)	5 TANK SEQUENTIAL FILTER
48-TA	1	-	2	-	-	-	2 TANK ALTERNATOR (SEE NOTE 3)
48-TB	1	2	1	2	1	2	2 TANK ALTERNATOR

D	ITEM NO. 3 WAS P/N 1074842	NONE	15SEP03	
REV.	DESCRIPTION	ECO	DATE	APVD
		16605 West Victor Rd New Berlin, WI 53151 262-326-0100 www.aq-matic.com		
SERIES 48 STAGER PROGRAMS AND MOUNTING DRAWING				
SCALE N/A	DRAWN MSM	DATE 11Apr01	DWG. NO. 1077882	

**PILOT CONTROL ASSEMBLY**

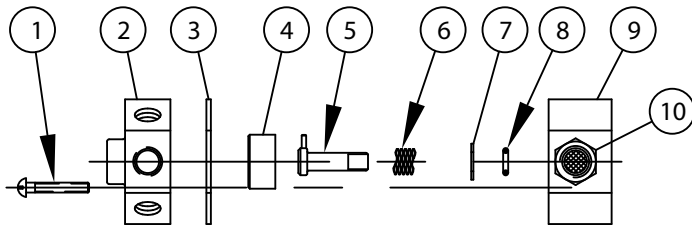

**OPTIONAL AUX. SWITCHES**

MAXIMUM OF TWO (2)

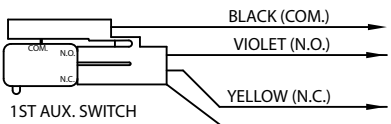
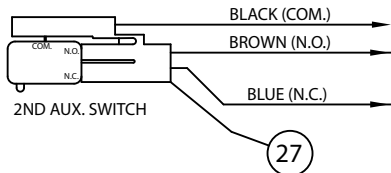

**SWITCH RATINGS**

- 11A 1/3HP
- 125, 250, 277 VAC
- 1/2A 125 VDC
- 1/4A 250 VDC
- 4A 125 VAC L

**STANDARD WIRING**

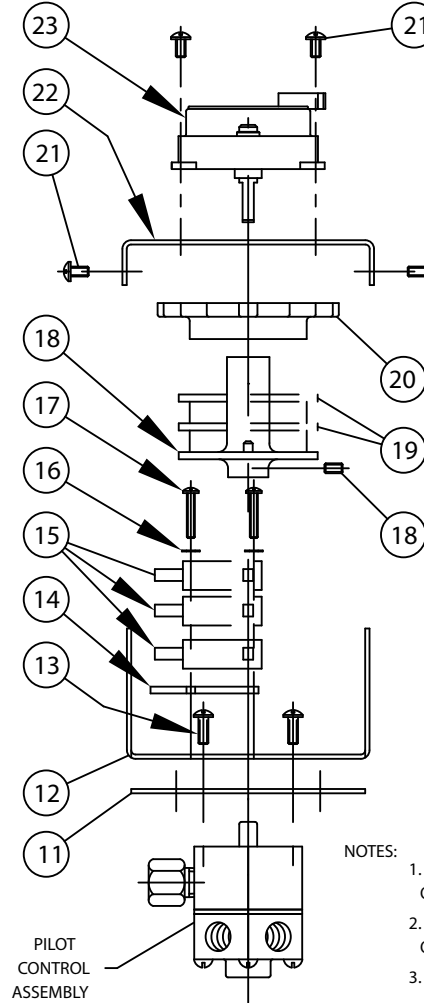
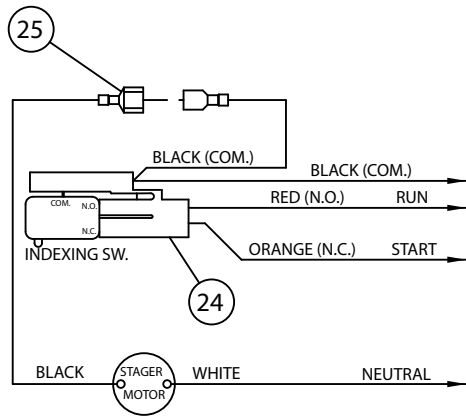

NOTES:

1. STAGER PROGRAM MUST BE SPECIFIED WHEN ORDERING THIS PART.
2. MUST SPECIFY IN WHICH POSITION(S) SWITCH OUTPUT(S) ARE REQUIRED.
3. SUPPLIED AS A KIT ONLY.

NO.	DESCRIPTION	PART NO.	QTY.
1	RD HD. MACH. SCR. (6-32 X 7/8")	1075759 (SCS-0075)	3
2	BACKPLATE	PER PROGRAM	1
3	GASKET (SEE NOTE 3)	1084171	1
4	STEMPLATE (SEE NOTE 3)	PER PROGRAM	1
5	STEMSHAFT	1070448	1
6	SPRING (SEE NOTE 3)	1076234	1
7	WASHER (SEE NOTE 3)	1074074 (41-F)	1
8	O-RING (SEE NOTE 3)	1071667 (ORB-010)	1
9	BONNET	1074793 (48-B)	1
10	FILTERED INLET (1/8" N.P.T.)	1074825 (48-Q)	1
11	MOUNTING PLATE GASKET	1075737	1
12	BOTTOM MOUNTING BRACKET	1070437	1
13	PAN HD. MACH. SCR. (6-32 X 3/8")	1072371 (SCS-0070)	4
14	INSULATOR	1075455 (58B019)	1
15	SWITCH	1075499 (58013)	1-3
16	LOCKWASHER (NO. 4)	1073593 (WAS-0015)	2
17	PAN HD. MACH. SCREW (4-40 THREAD)	1 SWITCH	1072369 (SCS-0064)
		2 SWITCHES	1075757 (SCS-0065)
		3 SWITCHES	1072389 (SCS-0151)
18	48-00 INDEXING CAM	1076245	1
	48-01 INDEXING CAM	1076244	
	48-03 INDEXING CAM	1076246	
	48-TA INDEXING CAM	1077932	
	ALL OTHERS (SEE NOTE 1)	1076243	
*CAMs INCLUDE 6-32 SET SCREW			
19	AUXILIARY CAM (SEE NOTE 2)	1075451 (58B017)	0-2
20	THUMB WHEEL	1075454 (58B018)	1
21	TAPTITE SCREW (6-32 X 1/4")	1075746	6
22	MOTOR MOUNTING BRACKET	1070436	1
23	MOTOR (4 WATTS MAX.)	115VAC 60HZ	1075748
		230VAC 50/60HZ	1075749
		24VAC 50/60HZ	1075750
		12VAC 50/60HZ	1075753
24	WIRE HARNESS (STANDARD)	1075464 (58B030)	1
25	MALE CONNECTOR	1075498 (58012)	1
26	WIRE HARNESS (1ST AUX. SWITCH)	1075501 (58015)	1
27	WIRE HARNESS (2ND AUX. SWITCH)	1075502 (58016)	1

**INTERNAL PARTS KITS**

STAGER PROGRAM	INTERNAL PARTS KITS STD. PROGRAMS	INTERNAL PARTS KITS INVERTED PROGRAMS
48-00		
48-01		
48-03		
48-04		
48-11		
48-12		
48-TA		
48-83		
48-84		
48-85		
48-TB		
48-SP	1084816 (48-IA-SP)	1081595 (48-IAB) 1081594 (48-IA-83I)

\* INTERNAL PARTS KITS INCLUDE ITEM NOS. 3, 4, 6, 7 & 8 ALONG WITH A SMALL PACKET OF SILICON COMPOUND

D	ITEM NO. 3 WAS P/N 1074842	NONE	15SEP03	
REV.	DESCRIPTION	ECO	DATE	APVD
		16605 Victor Rd New Berlin, WI 53151 262-326-0100 www.aq-matic.com		
<b>SERIES 48 STAGER ASSEMBLY ASSEMBLY DRAWING</b>				
SCALE 3/8	DRAWN MSM	DATE 11APR01	DWG. NO. 1077882	

Form No. 1077881